

Agenda Item 9(b)
SMMC
5/23/16

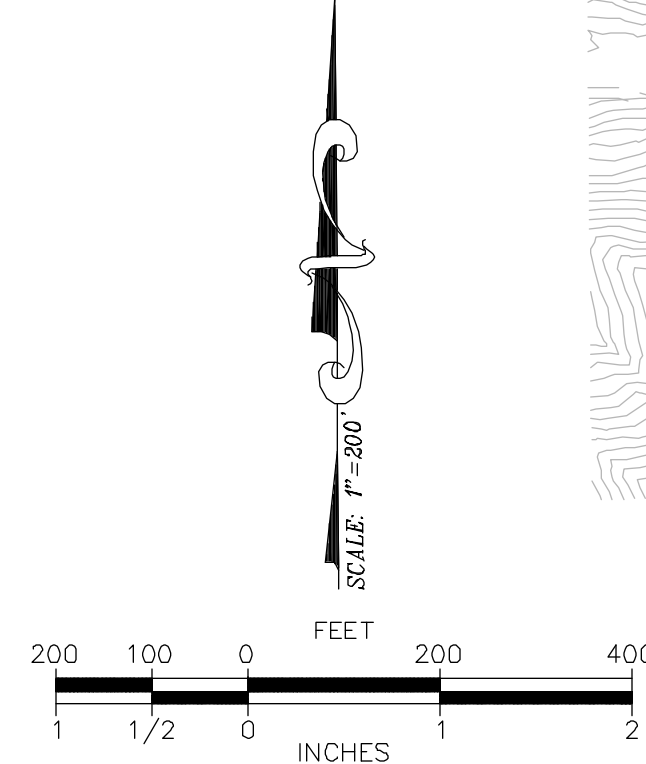
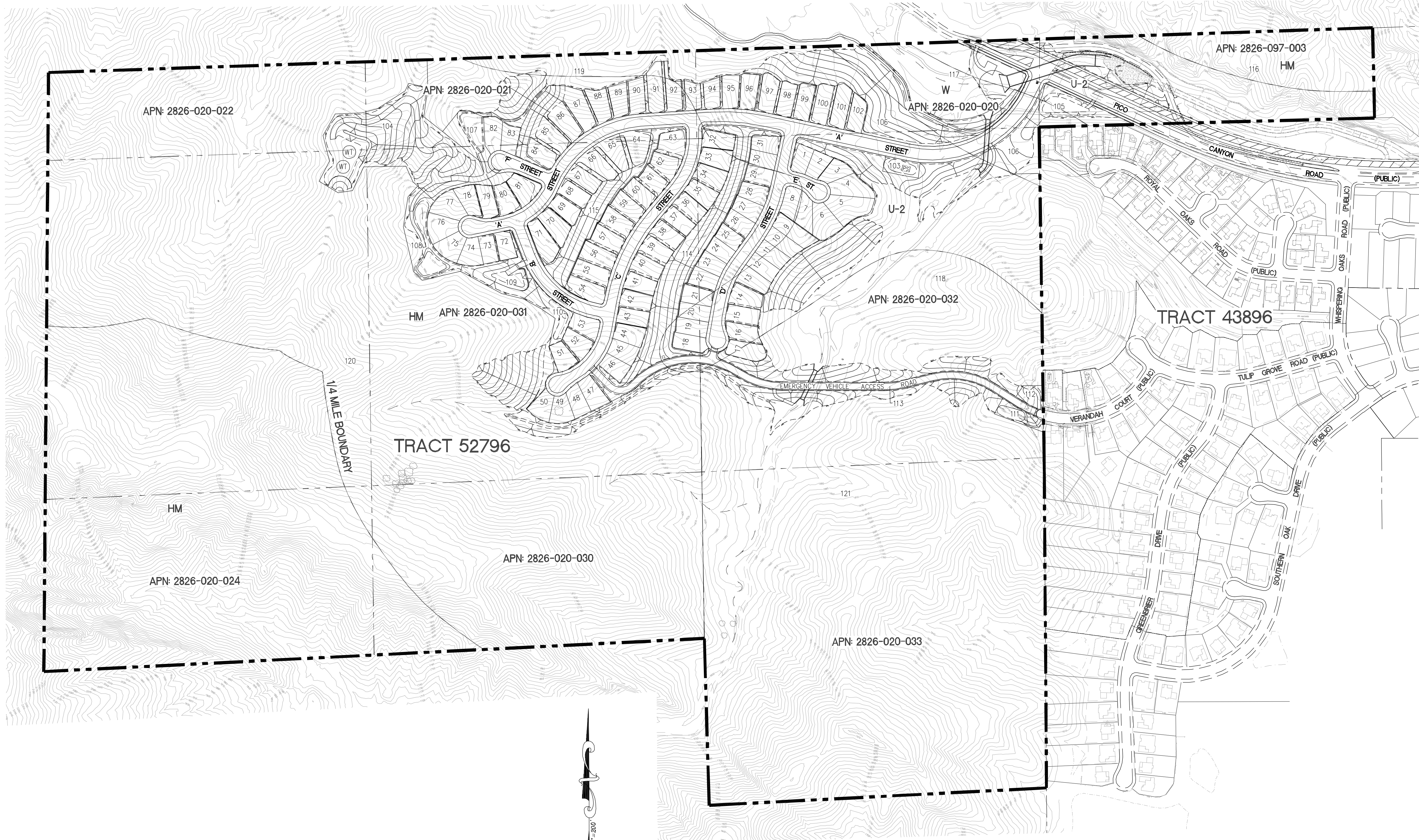
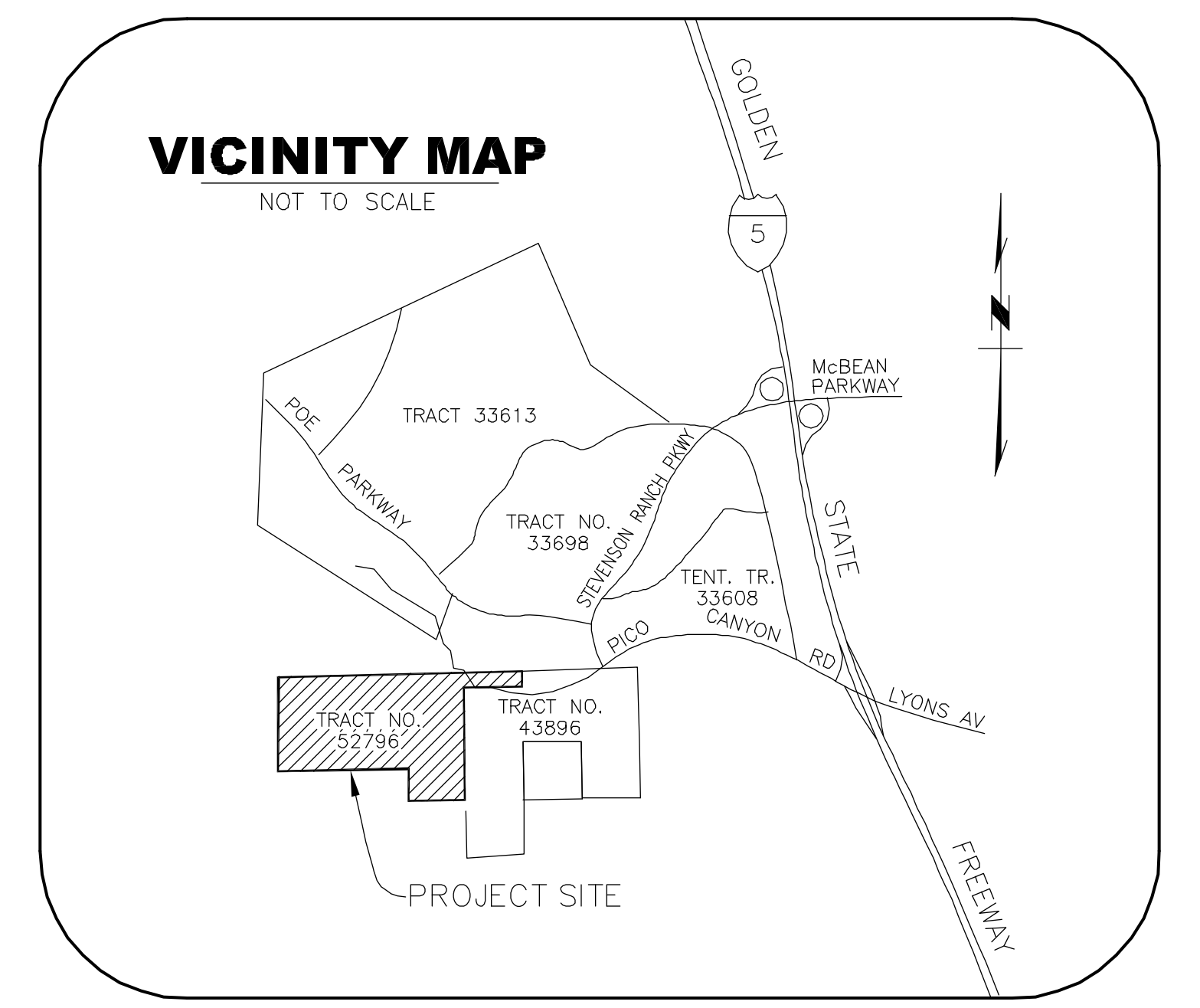

GENERAL NOTES

- GRADE ELEVATIONS SHOWN ON THIS VTM ARE APPROXIMATE. THE ELEVATIONS MAY CHANGE BY 3 FEET. ELEVATION CHANGES MAY BE GREATER THAN 3 FEET BUT ONLY IF DETERMINED BY DWP AND DRP THAT THE REVISIONS ARE CONSISTENT WITH THE INTENT OF THE SUBDIVISION MAP APPROVAL.
- LOT LINES CAN BE ADJUSTED TO THE SATISFACTION OF DRP PROVIDED NO ADDITIONAL DEVELOPMENT LOTS ARE CREATED. THE DEGREE OF ADJUSTMENT SHALL BE CONSISTENT WITH THE INTENT OF THE SUBDIVISION MAP ACT.
- ALIGNMENT AND GEOMETRICS OF STREETS AND TRAILS ARE APPROXIMATE. ADJUSTMENTS TO TRAILS CAN BE MADE WITH APPROVAL BY DRP AND THE PARKS AND RECREATION DEPARTMENT.
- PERMISSION IS REQUESTED TO COMBINE LOTS.
- PERMISSION IS REQUESTED TO RECORD ADDITIONAL OPEN SPACE LOTS.
- PERMISSION IS REQUESTED TO RECORD ADDITIONAL UTILITY LOTS AND PROVIDE MAINTENANCE EASEMENTS TO THE SATISFACTION OF THE DPM AND DRP.
- PERMISSION IS REQUESTED TO MASS GRADE.
- PROPOSED STREET GRADING IS APPROXIMATE ONLY AND SUBJECT TO ADJUSTMENTS PENDING DETERMINATION OF FINAL DEVELOPMENT LAYOUT AND PLANS.
- PERMISSION IS REQUESTED TO PROVIDE RIGHT OF WAY RETURN GRADE OF 1% AT ALL LOCAL STREET INTERSECTIONS AND 2% FT WHERE ALL PLANNED HIGHWAYS INTERSECT OR WHERE ONE OF THE ROADS SERVES A COMMERCIAL OR INDUSTRIAL DEVELOPMENT.
- ALL DIMENSIONS SHOWN ARE APPROXIMATE.
- TOPO COMPILED FROM DATA FLOWN DECEMBER, 2013.
- ADDITIONAL RIGHT OF WAY MAY BE DEDICATED AS REQUIRED TO THE SATISFACTION OF PUBLIC WORKS.
- HOMEOWNERS ASSOCIATION TO BE ESTABLISHED TO MAINTAIN COMMON AREA OPEN SPACE.
- TOTAL STREET FRONTAGE (A-F STREETS) IS 11,100 LF.

SPECIAL NOTES

1. WATER QUALITY BASINS WILL PROVIDE FOR THE TREATMENT OF STORM WATER RUNOFF PER THE APPROVED DRAINAGE CONCEPT.

PROJECT SUMMARY:

GROSS AREA: 230.5 Acres
 NET AREA: 228.8 Acres
 (GROSS AREA-PICO CANYON ROAD AREA)
 TOTAL LOTS: 121
 TOTAL RESIDENTIAL D.U.: 102 DU
 TOTAL OFFICE/COMMERCIAL: NONE
 EXISTING ZONING: A-2-2
 PROPOSED ZONING: A-2-2
 EXISTING LAND USE: U-2, HM, W
 PROPOSED LAND USE: U-2, HM, W
 APN: 2826-020-020, 021, 022, 023, 024
 2826-020-030, 031, 032, 033
 2826-097-003
 T.G. PAGE 4640, GRIDS A-1, A-2, B-1, B-2
 ESTIMATED EARTHWORK: 1,300,000 CY CUT
 1,300,000 CY FILL
 OVEREXCAVATION: 300,000 CY
 OAK TREES TO BE REMOVED: 1 TREE
 OAK TREES TO BE ENCRoACHED: 0 TREE
 OAK TREES TO REMAIN: 14 TREES
 TOTAL OAK TREES: 15

RELATED ENTITLEMENTS

CONDITIONAL USE PERMIT NO. 00-136
 OAK TREE PERMIT NO. 00-136

LOT SUMMARY

LOT NUMBERS	NO. OF LOTS	TYPE	TOTAL ACREAGE
1-102	102	SINGLE FAMILY	21.2 AC
103-104	2	WATER TANK/PUMP STATION	3.8 AC
105-112	8	WOT BASINS	4.3 AC
113	1	FIRE ACCESS ROAD	1.4 AC
114-121	8	OPEN SPACE (LANDSCAPE & NATURAL)	190.1 AC
PUBLIC STREETS	N/A	N/A	9.7 AC
TOTAL	121		230.5 AC

UTILITIES & SERVICES:

- SEWER: L.A. COUNTY SANITARY DISTRICT #32
- WATER: VALENCIA WATER COMPANY
- GAS: SO. CALIFORNIA GAS CO.
- ELECTRICAL: SO. CALIFORNIA EDISON CO.
- TELEPHONE: AT&T
- SCHOOLS: NEWHALL ELEMENTARY SCHOOL DISTRICT, HART HIGH SCHOOL DISTRICT
- FIRE: L.A. COUNTY FIRE DEPARTMENT
- POLICE: L.A. COUNTY SHERIFF
- T.V.: STEVENSON RANCH CABLE

RECORD OWNER

ADJIN GENERAL TRUST
 TRACY WOODFORD, TRUSTEE
 5143 SUNSET BLVD.
 LOS ANGELES, CA 90027-5715
 323-666-1910
 JAS143@ACBELL.NET

APPLICANT

LENNAR HOMES
 980 MONTECITO DRIVE, SUITE 302
 CORONA, CA 92789
 (951)817-3542

ENGINEER:

ALLIANCE LAND PLANNING & ENGINEERING
 2248 FARADAY AVENUE
 CARLSBAD, CA 92008
 PHONE (760) 431-9896 FAX (760) 431-8802

LEGAL DESCRIPTION:

LOTS 3, 2, 3, 4, 5 AND A PORTION OF LOT 6, AND PORTIONS OF THE NORTHEAST QUARTER, SOUTHWEST QUARTER, NORTHWEST QUARTER AND SOUTHWEST QUARTER, ALL IN SECTION 6, TOWNSHIP 3 NORTH, RANGE 16 WEST, SAN BERNARDINO MERIDIAN, ACCORDING TO THE OFFICIAL PLAT OF SAID LAND, IN THE COUNTY OF LOS ANGELES, STATE OF CALIFORNIA.

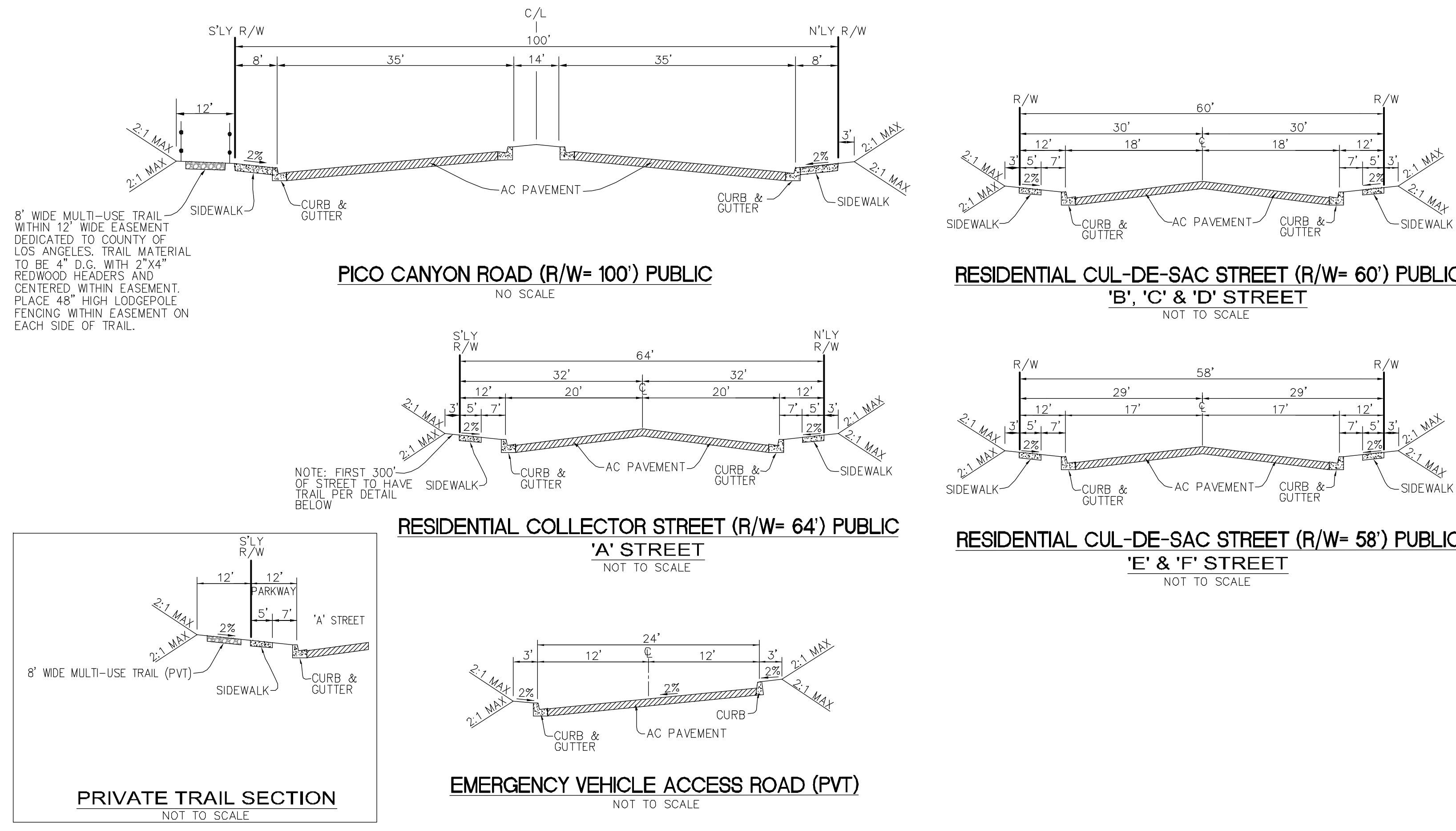
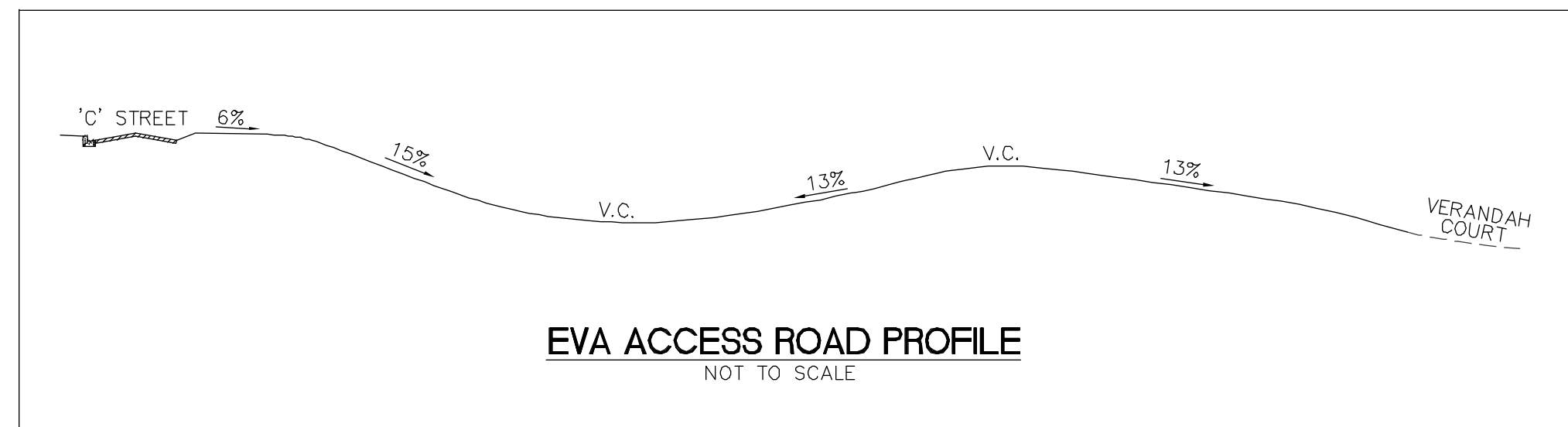

STREET CENTERLINE CURVE TABLE

NO	DELTA	RADIUS	LENGTH	TANGENT
01	Δ= 77°21'01"	425.00'	573.76'	340.00'
02	Δ= 16°08'39"	800.00'	225.42'	113.00'
03	Δ= 63°18'55"	400.00'	442.02'	247.00'
04	Δ= 55°19'25"	250.00'	241.40'	131.00'
05	Δ= 58°56'25"	345.00'	354.90'	195.00'
06	Δ= 50°59'46"	250.00'	222.51'	119.00'
07	Δ= 30°04'50"	700.00'	367.50'	188.00'
08	Δ= 44°00'40"	300.00'	230.44'	121.00'
09	Δ= 23°29'54"	500.00'	205.06'	104.00'
10	Δ= 25°42'43"	350.00'	157.07'	80.00'
11	Δ= 28°08'22"	200.00'	98.23'	50.00'

EASEMENTS:

PRELIMINARY TITLE REPORT: NORTH AMERICAN TITLE COMPANY REPORT NO. 1224993 DATED NOVEMBER 14, 2014

TITLE REPORT ITEM NO.	OWNER	PURPOSE	REFERENCE	FUTURE DISPOSITION	COMMENTS
14,18,24	UNITED STATES GOVERNMENT	DITCH/RESERVOIRS	BOOK 12, PAGE 104 OF PATENTS	TO REMAIN	BLANKET EASEMENT
19	UNITED STATES GOVERNMENT	DITCH/RESERVOIRS	BOOK 13, PAGE 295 OF PATENTS	TO REMAIN	BLANKET EASEMENT
22	L.A. COUNTY FLOOD CONTROL DISTRICT	FLOOD CONTROL/ACCESS	TRACT MAP 43896 BOOK 1260, PAGES 29-34 JUNE 20, 2001	TO REMAIN	
25	GEORGE WOHAM	ROAD, ELEC. LINES	BOOK 17319, PAGE 381 DECEMBER 10, 1939	TO REMAIN	BLANKET EASEMENT OVER EAST HALF OF EXISTING PARCEL, 5
32	LOS ANGELES COUNTY	ROADS	AP MAP 2826-97	TO BE VACATED WITH TRACT MAP	
33	STANDARD OIL COMPANY	PIPELINES	BOOK 666, PAGE 121 APRIL 12, 1918	TO BE VACATED	NOT PLOTTABLE
34	SOCAL GAS COMPANY	PIPELINES	BOOK 4489, PAGE 232 SEPTEMBER 1, 1929	TO REMAIN	
35	LOS ANGELES COUNTY	ROAD/HIGHWAY	BOOK 20073, PAGE 311 JUNE 28, 1943	TO BE VACATED WITH TRACT MAP	
36	PACIFIC LIGHTING COMPANY	PIPELINES	BOOK 32618, PAGE 336 MARCH 28, 1950	TO REMAIN	
37	SOCAL EDISON COMPANY	PIPELINES	BOOK 53600, PAGE 420 FEBRUARY 5, 1957	TO REMAIN	
38	SOCAL EDISON COMPANY	PIPELINES	INSTR. NO. 4521 OCTOBER 28, 1965	TO REMAIN	INDETERMINATE LOCATION
42	SOCAL GAS COMPANY	PIPELINES	INSTR. NO. 01-2122764 NOVEMBER 6, 2001	TO REMAIN	
43	L.A. COUNTY FLOOD CONTROL DISTRICT	FLOOD CONTROL DRAINAGE, ACCESS	TRACT MAP 43896-07 MB 1259, PAGES 50-57 MAY 30, 2001	PORTION TO BE VACATED WITH TRACT MAP	
44	LOS ANGELES COUNTY	SLOPE MAINTENANCE	INSTR. NO. 04-1738068 JULY 8, 2004	TO REMAIN	
45	MULTIPLE	ACCESS, UTILITIES	INSTR. NO. 05-0793905 APRIL 6, 2005	TO REMAIN	NOT PLOTTABLE

LEGEND:

- 1 PAD 1510 6,500 sf
- LOT NO.
- PAD ELEVATION
- LOT AREA (SQUARE FEET)
- PROJECT BOUNDARY
- PROPOSED RIGHT OF WAY
- PROPOSED EASEMENT
- EXISTING EASEMENT
- PROPOSED CONTOUR
- PROPOSED DAYLIGHT LINE
- PROPOSED STORM DRAIN
- PROPOSED SANITARY SEWER
- PROPOSED WATER
- PROPOSED STORM DRAIN INLET/OUTLET (TO BE MAINTAINED BY LACFD)
- PROPOSED CATCH BASIN
- EXISTING STORM DRAIN LINE
- EXISTING SEWER LINE
- EXISTING WATER LINE
- EXISTING OIL LINE
- EXISTING GAS LINE
- EXISTING OVERHEAD POWER LINE
- EXISTING POWER POLE
- PROPOSED RETAINING WALL
- 6' HIGH MAX. RETAINING WALL
- SEA LINE
- FEMA FLOODPLAIN
- CFGF LIMIT LINE
- ACOE LIMIT LINE
- ACOE LIMIT LINE
- SLOPE PROTECTION (TRM) TURF REINFORCEMENT MAT
- OAK TREE (TO BE ENCRoACHED)
- OAK TREE (TO BE REMOVED)
- OAK TREE (TO REMAIN)

BENCHMARK

COUNTY OF LA BM #13206
 R.L.B.M. TAG # 5 CB 8.2M W/O BOR @ SW CORN.
 LYONS AVE. & WILEY CANYON RD. 30.5M W/O &
 12.2M S/O C/L INT (NR W END CB)
 NEWHALL 2009 ELEV = 1265.354

ALLIANCE
 LAND PLANNING & ENGINEERING INC.
 2248 FARADAY AVE.
 CARLSBAD, CA 92008
 TEL: (760) 431-8802
 FAX: (760) 431-8802
 5215 TORREY ROAD
 VALLEJO, CA 94590
 TEL: (681) 999-2760

PREPARED FOR:
LENNAR HOMES
 980 MONTECITO DRIVE, SUITE 302
 CORONA, CA 92789
 (951)817-3542

REPRESENTATIVE: CHERYL THOMPSON

PLANS PREPARED BY:
ALLIANCE LAND PLANNING & ENGINEERING INC.
 2248 FARADAY AVE.
 CARLSBAD, CA 92008
 (760) 431-9896

PLANS PREPARED UNDER THE DIRECTION OF:

 CRAIG N. WHITTEKER R.C.E. 51929 DATE: 8/27/15

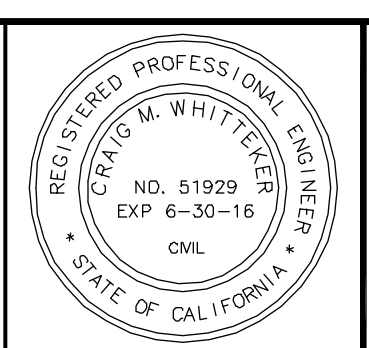

SHEET 1 COUNTY OF LOS ANGELES 2 SHEETS

MAJOR LAND DIVISION
 VESTING TENTATIVE TRACT MAP
 NO. 52796

LOCATED IN THE UNINCORPORATED AREA OF THE
 COUNTY OF LOS ANGELES, STATE OF CALIFORNIA

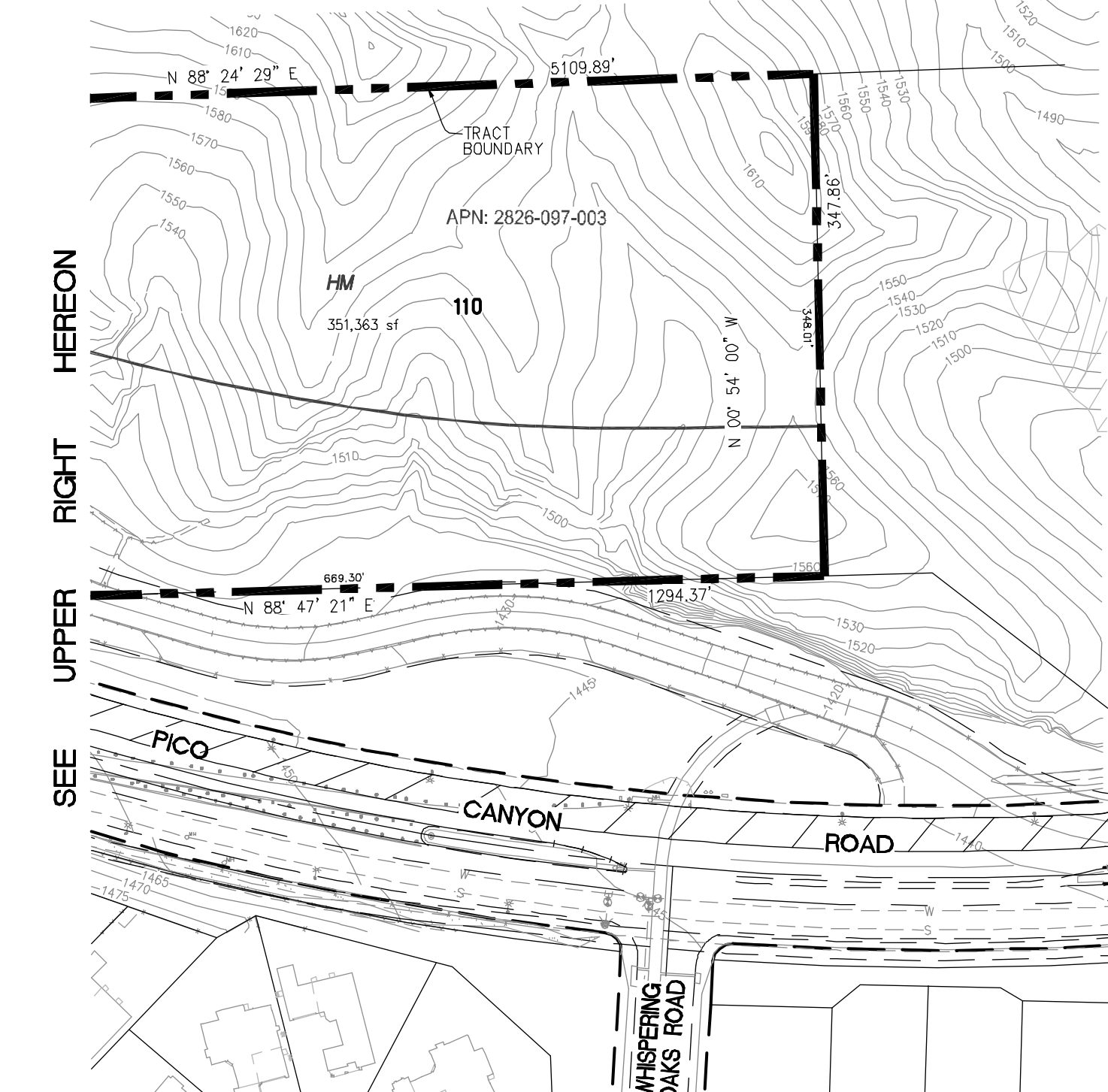
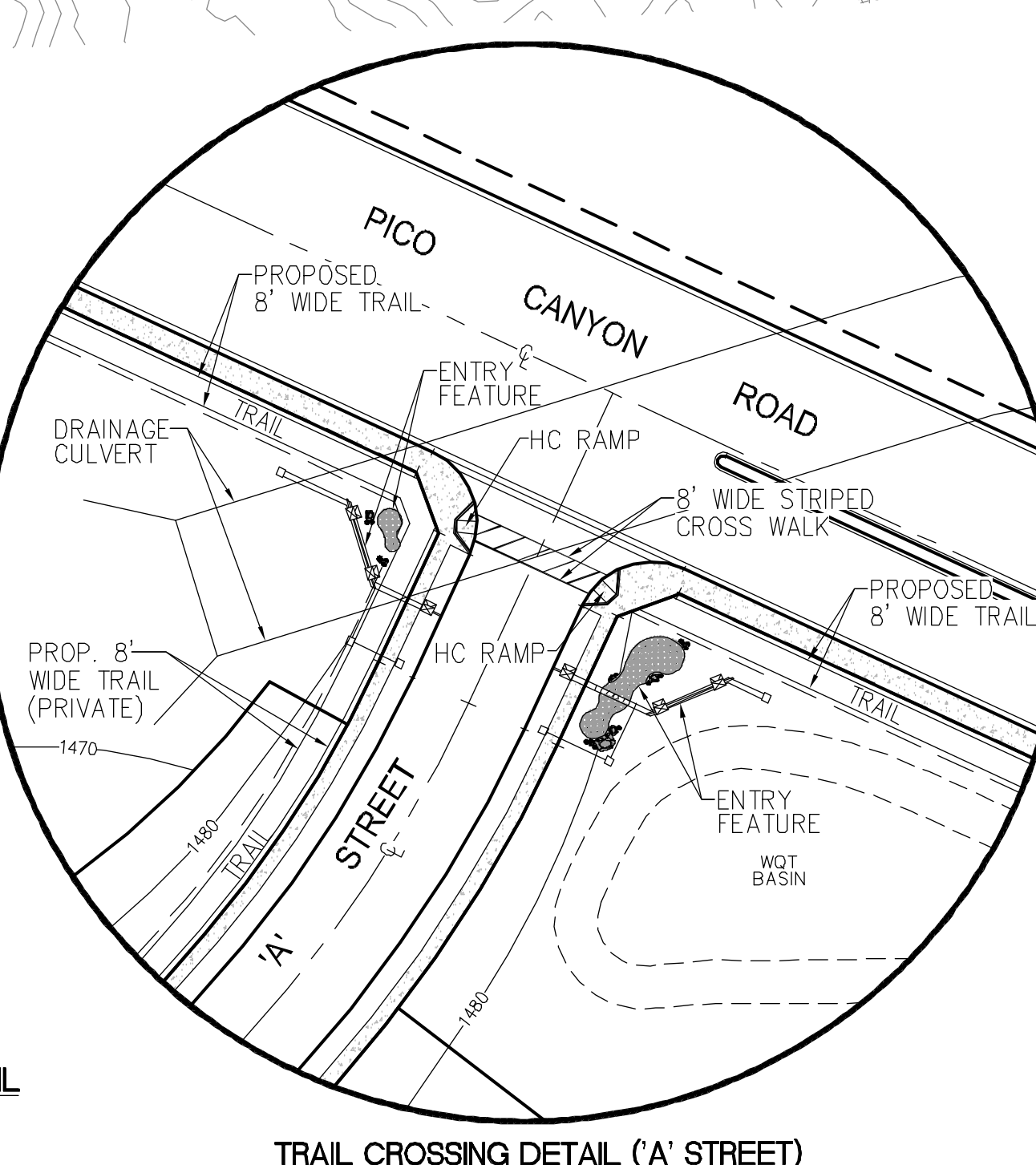
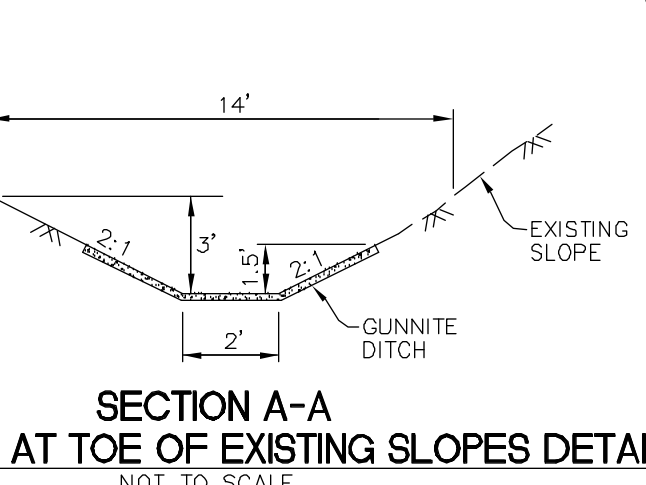
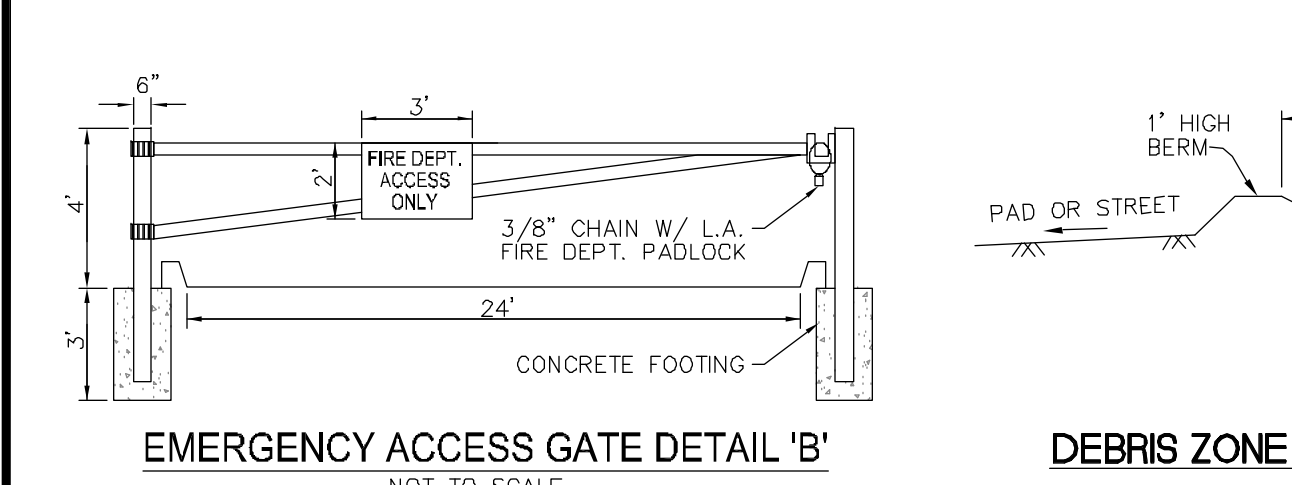
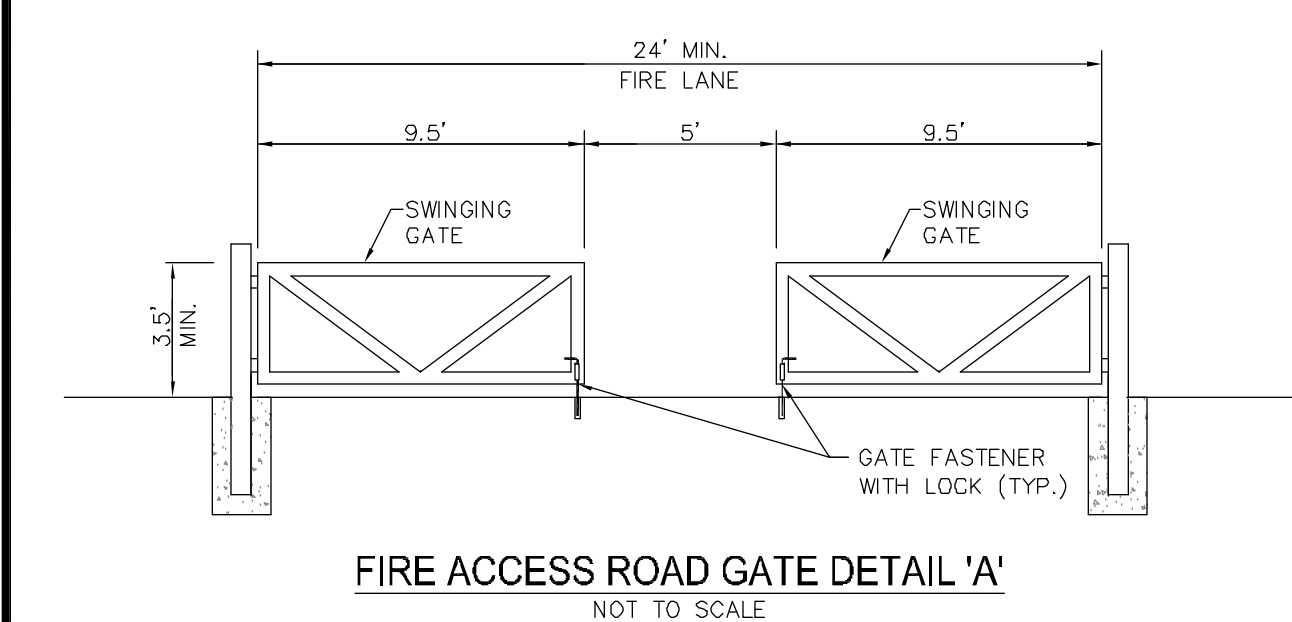
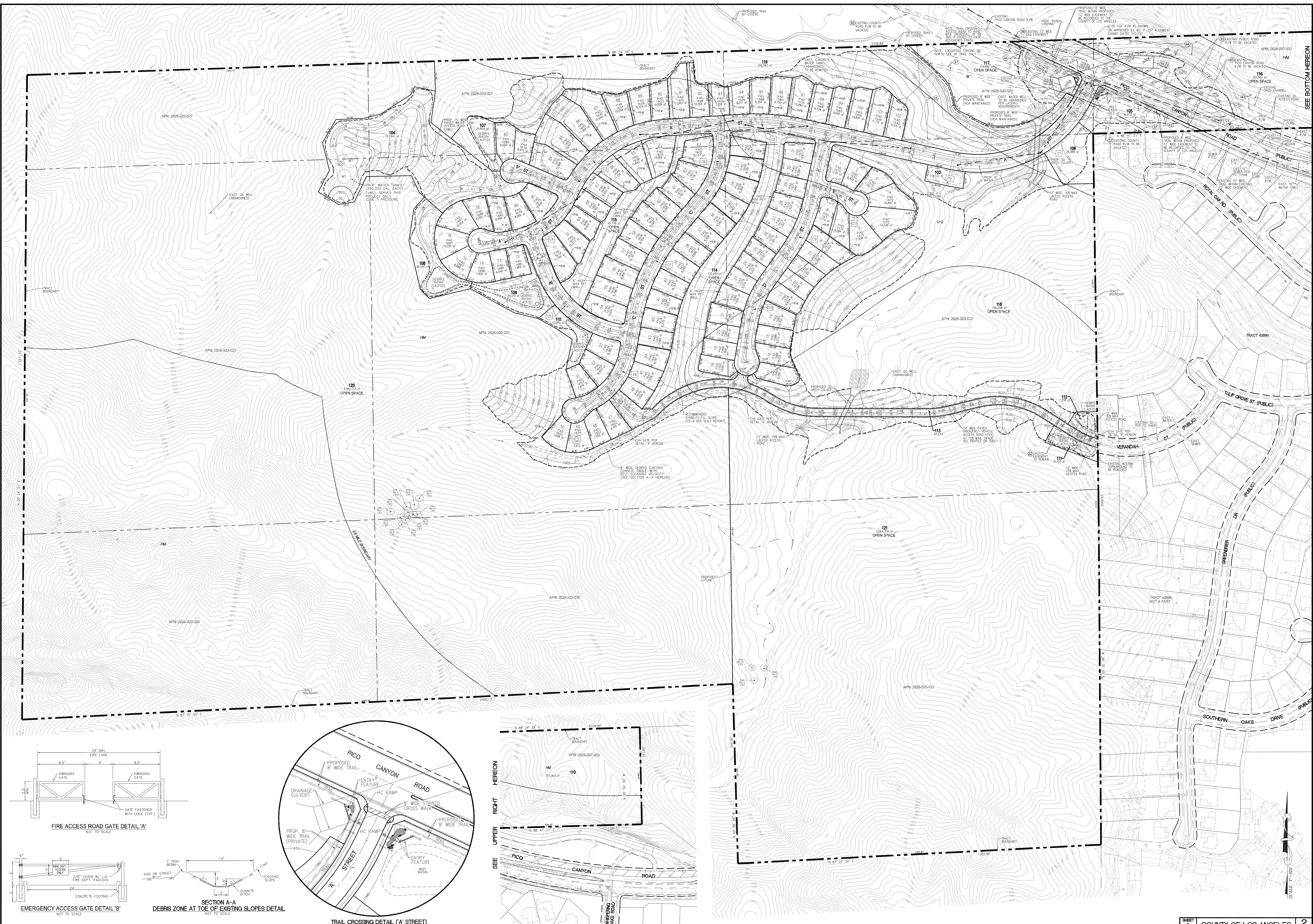

2248 FARADAY AVE.
 CARLSBAD, CA 92008
 FAX: (760) 431-8802
 52415 TOWNLEY ROAD
 VALLEJO, CA 94590
 TEL: (681) 799-2760

PREPARED FOR:
LENNAR HOMES
 980 MONTECITO DRIVE, SUITE 302
 CORONA, CA 92879
 (951)817-3542

REPRESENTATIVE: CHERYL THOMPSON

PLANS PREPARED BY:
ALLIANCE LAND PLANNING & ENGINEERING INC.
 2248 FARADAY AVE.
 CARLSBAD, CA 92008
 (760) 431-9890

PLANS PREPARED UNDER THE DIRECTION OF:
Craig M. Whitteker
 CRAIG M. WHITTEKER, R.C.E. 51929

DATE: 8/27/15

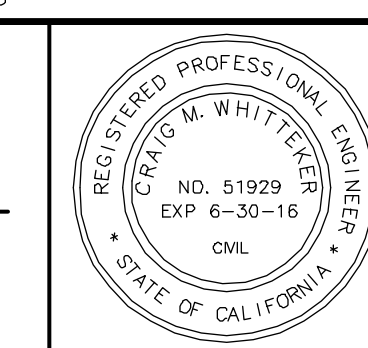

RECEIVED:
 DEPT. OF REGIONAL PLANNING
 TRK2016 TENTATIVE PG.2
 DATE: 10 SEP 2015

NO.	DATE	REVISIONS	BY	APPR.

SHEET 2 COUNTY OF LOS ANGELES 2
MAJOR LAND DIVISION
VESTING TENTATIVE TRACT MAP
NO. 52796

LOCATED IN THE UNINCORPORATED AREA OF THE COUNTY OF LOS ANGELES, STATE OF CALIFORNIA